

2023 WS Finals Show

Team Showmanship

Show Date:

www.HorseShowPatterns.com

www.HorseShowPatterns.com

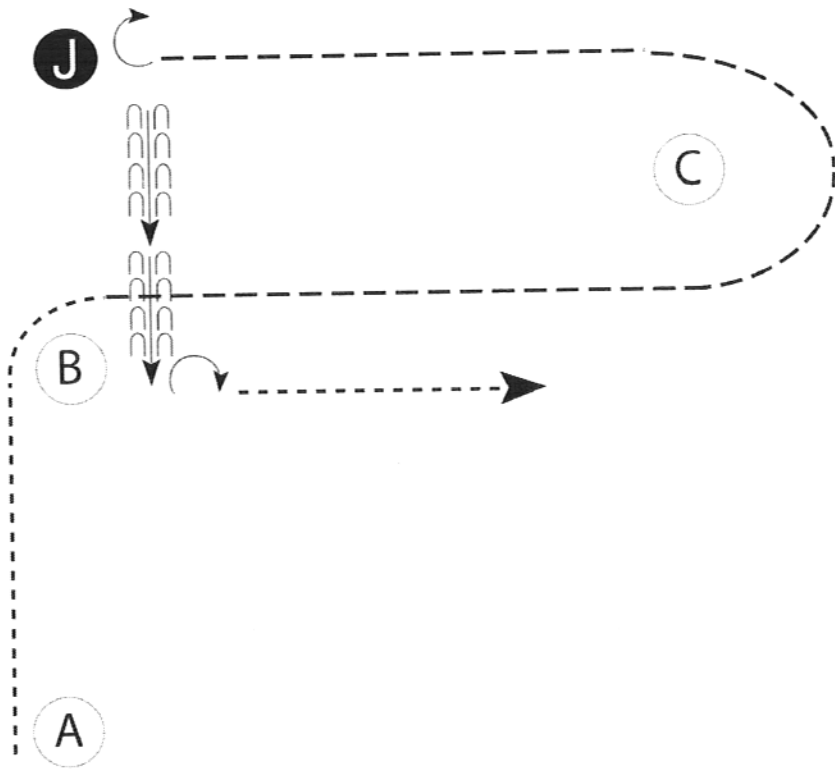

Be ready at A.

1. Walk to and around B.
2. Trot from B, around C and to judge.
3. Stop and set up for inspection.
4. When dismissed, perform a 1/4 turn.
5. Back to B.
6. Turn 1/4 turn and walk to exit.

Follow the instructions of your ring steward.

Walk -----
Trot - - - - -
Back ← [back pattern]
Marker (B)
Judge (J)

[S/2-36]

Pattern Provided by:

2023 WS Finals Show

Team Hunt seat

Show Date:

www.HorseShowPatterns.com

www.HorseShowPatterns.com

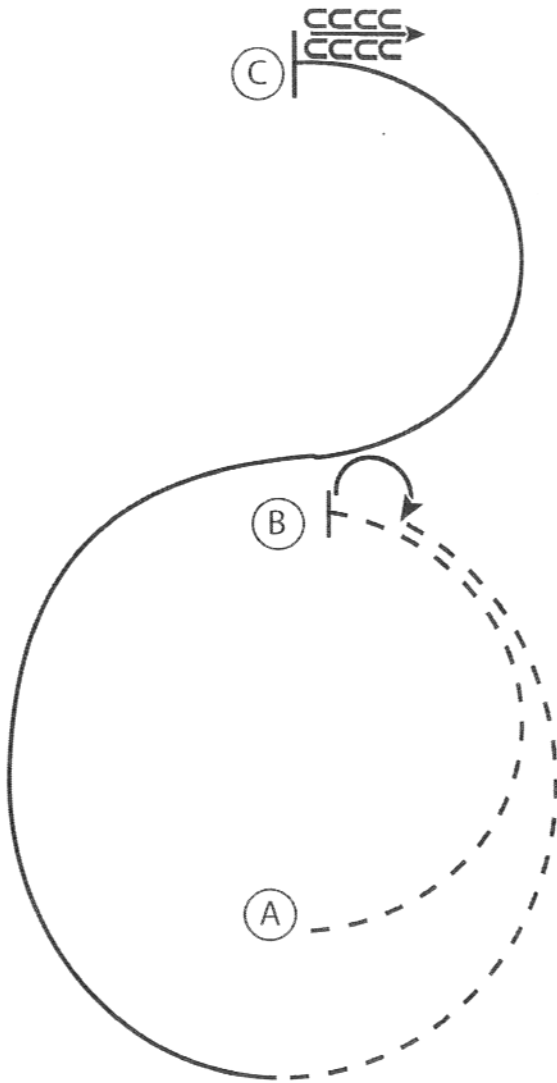

1. Posting trot half circle A to B
2. At B stop and perform a 180 degree turn to the right on the forehand
3. Posting trot half circle B to A
4. At A canter a half circle to B on the left lead
5. At B maintain the left lead in a half circle to C
6. At C stop and back 4 steps

Walk
Trot	- - - - -
Extended Trot	- - - - -
Canter	—————
Leg Yield	
Lead Change	↘
Back	← ← ←
Marker	(B)
Sidepass	←- - - ->

[HSE/2-7]

Pattern Provided by:

2023 WS Finals Show

Team Horsemanship

Show Date:

www.HorseShowPatterns.com

www.HorseShowPatterns.com

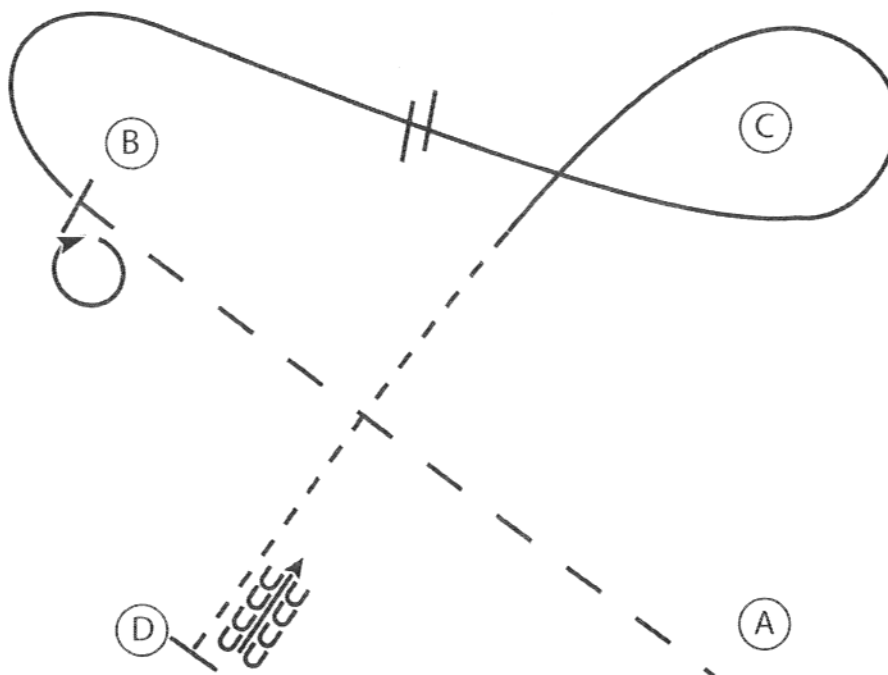

1. Extend the jog A to B
2. Stop at B and perform a 360 degree turn to the right
3. Lope on the right lead around B
4. Half way between B and C change leads and continue to and around C
5. Jog halfway between C and D
6. At D stop and back

Walk
Jog	-----
Extended Jog	-----
Lope	—————
Leg Yield	
Lead Change	↘
Back	←←←←← ←←←←←
Marker	(B)
Sidepass	←←←←←

[WH/2-27]

Pattern Provided by:

2023 WS Finals Show

Class 1 and 11

Show Date:

www.HorseShowPatterns.com

www.HorseShowPatterns.com

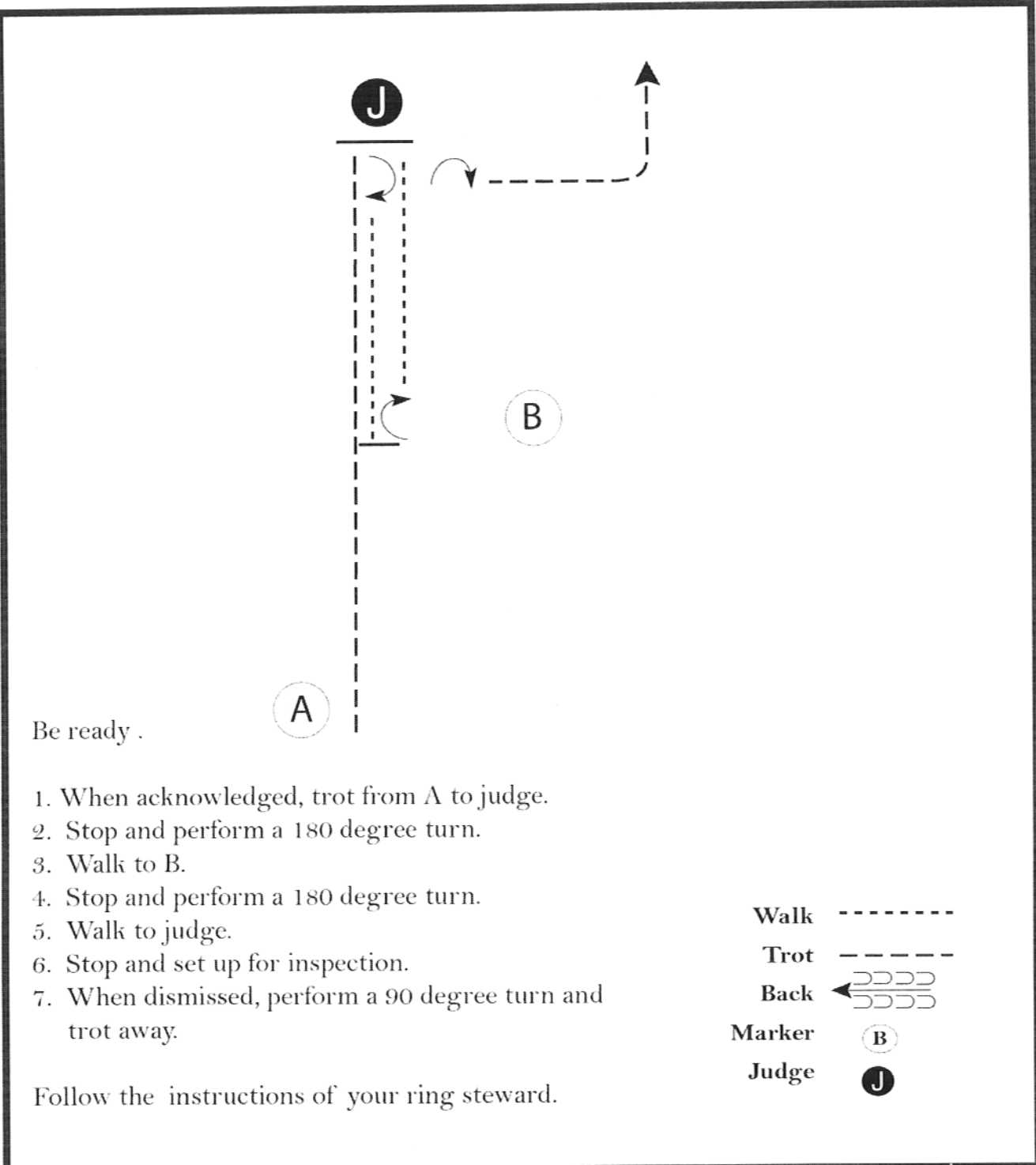

Be ready .

1. When acknowledged, trot from A to judge.
2. Stop and perform a 180 degree turn.
3. Walk to B.
4. Stop and perform a 180 degree turn.
5. Walk to judge.
6. Stop and set up for inspection.
7. When dismissed, perform a 90 degree turn and trot away.

- Walk -----
- Trot - - - - -
- Back ←
- Marker ○ B
- Judge ○ J

Follow the instructions of your ring steward.

[S/1-90]

Pattern Provided by:

2023 WS Finals Show

Class 2-12-13

Show Date:

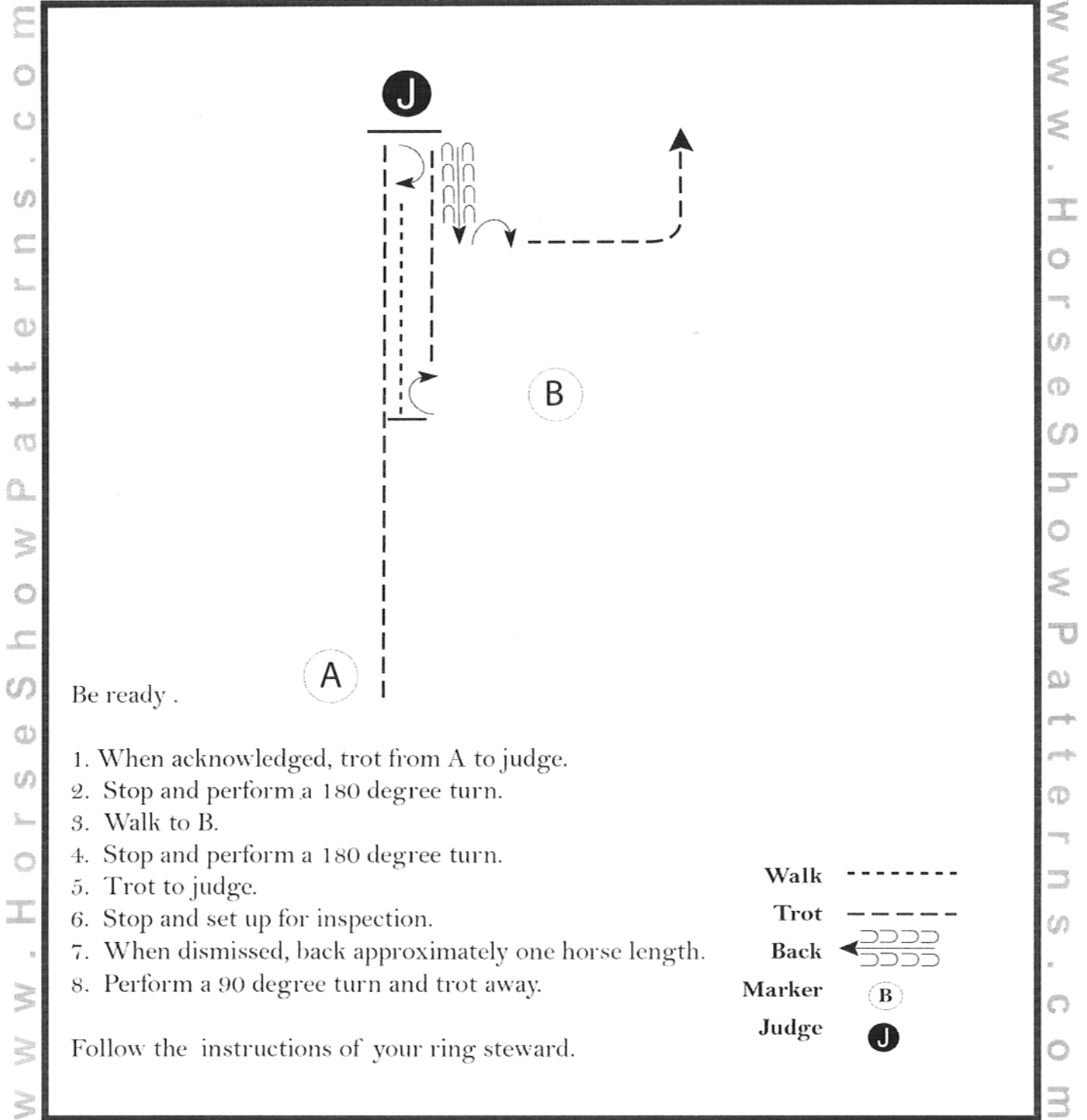

[S/2-90]

Pattern Provided by:

2023 WS Finals Show

Class 3-14

Show Date:

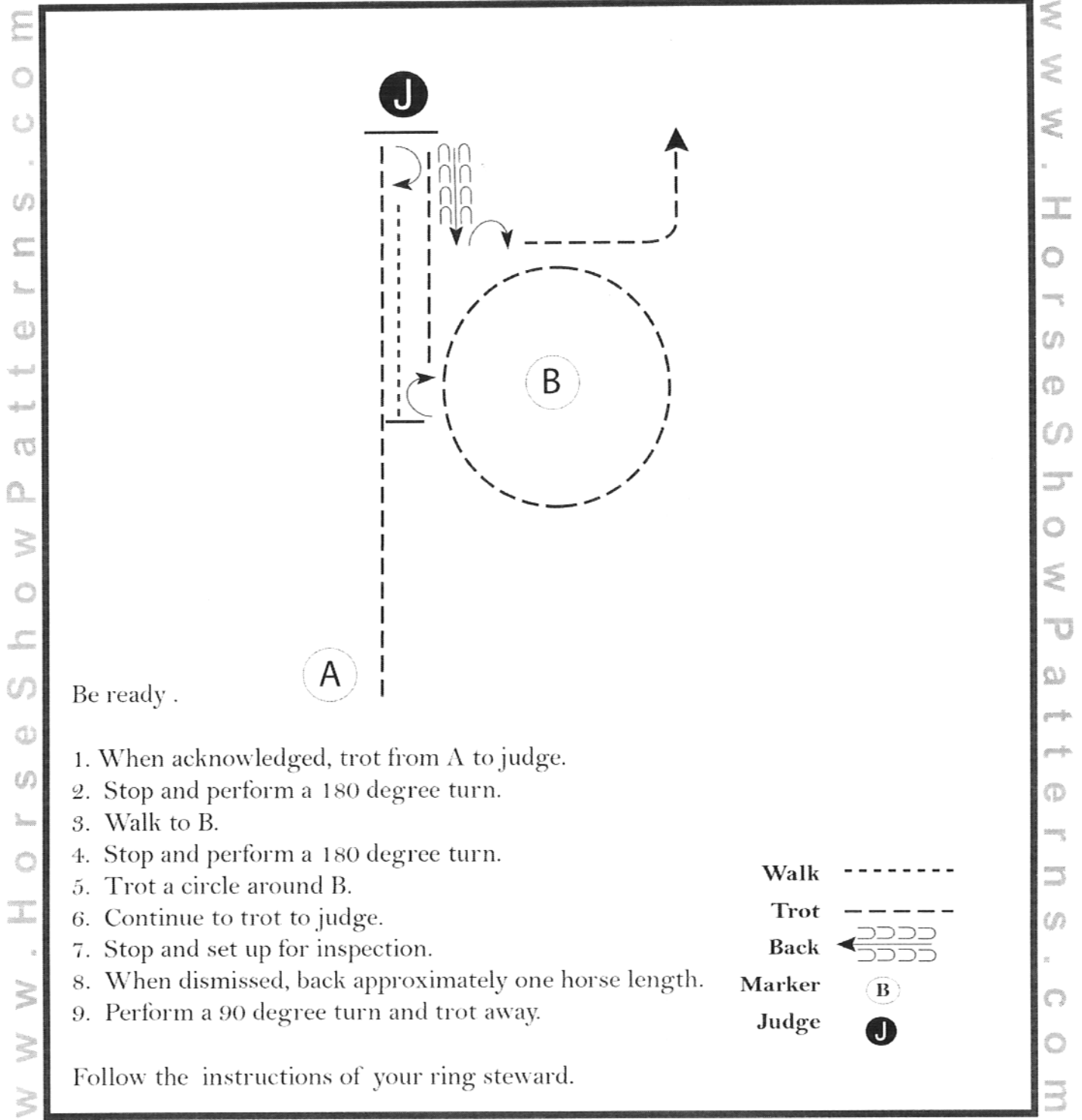

Be ready .

1. When acknowledged, trot from A to judge.
2. Stop and perform a 180 degree turn.
3. Walk to B.
4. Stop and perform a 180 degree turn.
5. Trot a circle around B.
6. Continue to trot to judge.
7. Stop and set up for inspection.
8. When dismissed, back approximately one horse length.
9. Perform a 90 degree turn and trot away.

Walk	-----
Trot	- - - - -
Back	← ~ ~ ~ ~ ~ ~ ~ ~ ~ ~
Marker	⊙ B
Judge	● J

Follow the instructions of your ring steward.

[S/3-90]

Pattern Provided by:

2023 WS Finals Show

Class 6 and 8

Show Date:

www.HorseShowPatterns.com

www.HorseShowPatterns.com

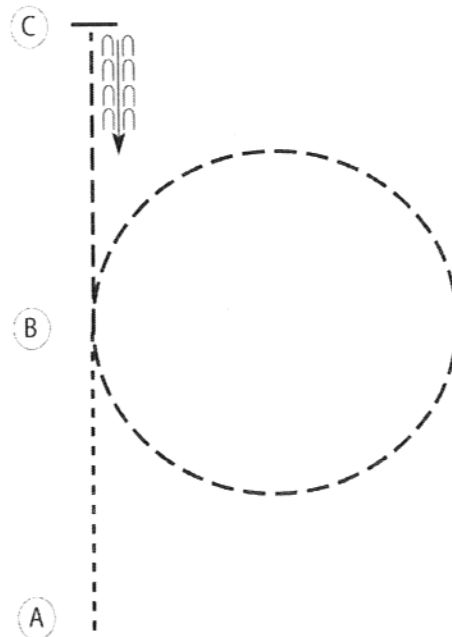

Be ready at A.

1. Walk from A to B.
2. At B, perform a posting trot circle to the right on the proper diagonal.
3. Return to B and perform a sitting trot to C.
4. Stop at C and back approximately one horse length.

Follow the instructions of your ring steward.

Walk	-----
Trot	- - - - -
Extended Trot	=====
Canter	—————
Leg Yield	
Lead Change	—/—
Back	← C C C C C
Marker	Ⓚ
Sidepass	← - - - - →
Hand Gallop	———

[HSE/WT-32]

Pattern Provided by:

2023 WS Finals Show

Class 9-15

Show Date:

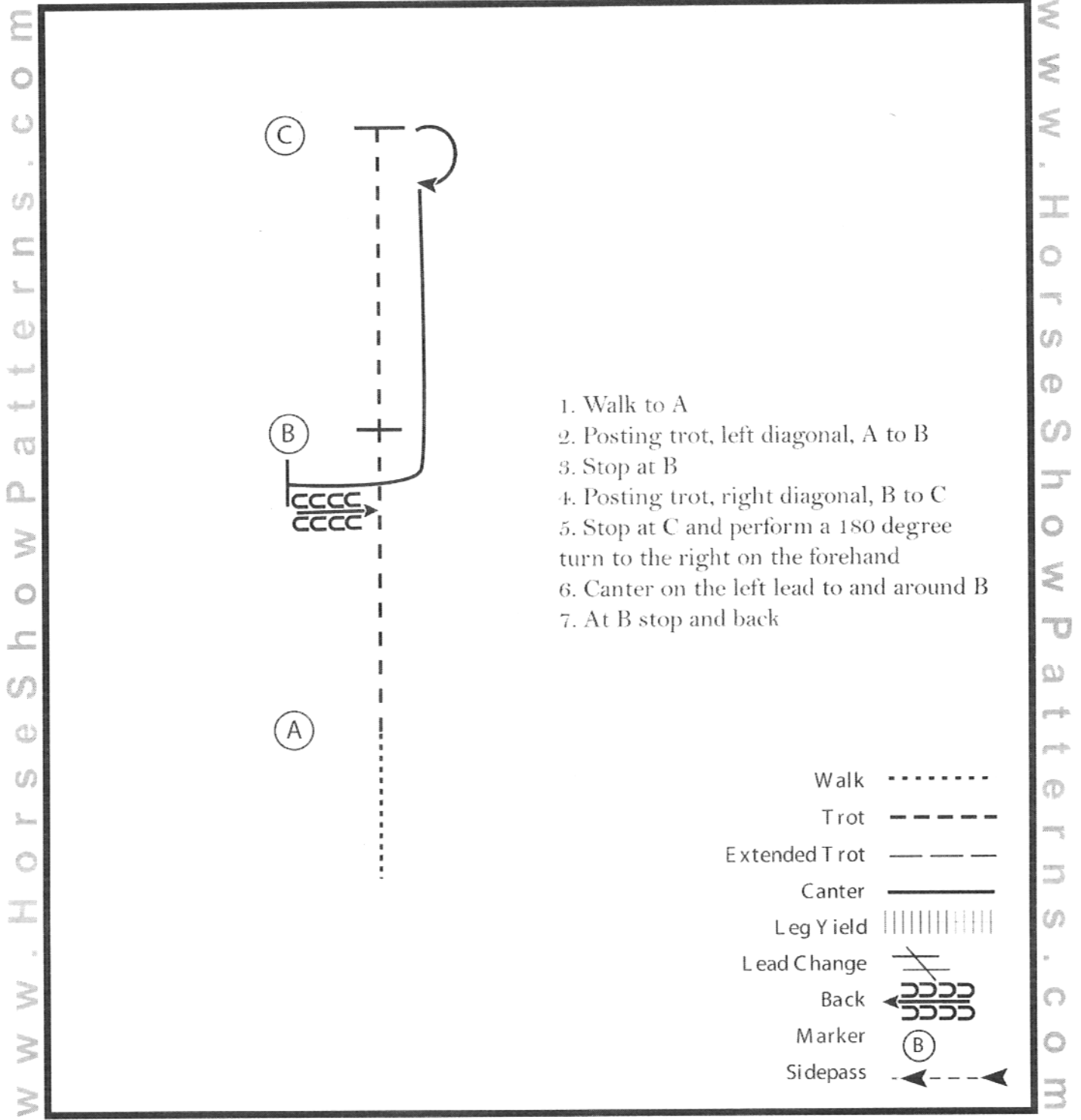

1. Walk to A
2. Posting trot, left diagonal, A to B
3. Stop at B
4. Posting trot, right diagonal, B to C
5. Stop at C and perform a 180 degree turn to the right on the forehand
6. Canter on the left lead to and around B
7. At B stop and back

Walk
Trot	-----
Extended Trot	-----
Canter	—————
Leg Yield	
Lead Change	—/—
Back	← CCCC CCCC
Marker	⊙ (B)
Sidepass	←-----←

[HSE/2-8]

Pattern Provided by:

2023 WS Finals Show

Class 10-16-17-18-19-20

Show Date:

www.HorseShowPatterns.com

www.HorseShowPatterns.com

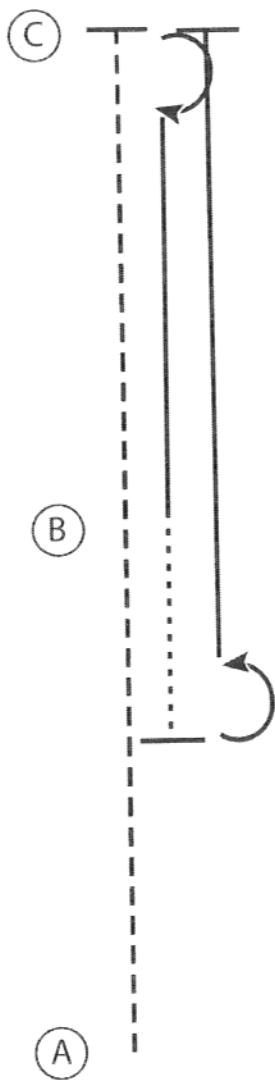

1. Posting trot right diagonal A to B
2. Posting trot left diagonal B to C
3. Stop at C and perform a 180 degree turn to the right on the hindquarter
4. Canter on the right lead C to B
5. At B walk towards A
6. When halfway to A stop and perform a 180 degree turn to the left on the hindquarter
7. Canter on the left lead to C
8. Stop at C

Walk
Trot	-----
Extended Trot	-----
Canter	—————
Leg Yield	
Lead Change	↘↙
Back	←←←←←
Marker	⊙
Sidepass	←-----

[HSE/3-6]

Pattern Provided by:

2023 WS Finals Show

Class 85-86-87-88-89

Show Date:

www.HorseShowPatterns.com

www.HorseShowPatterns.com

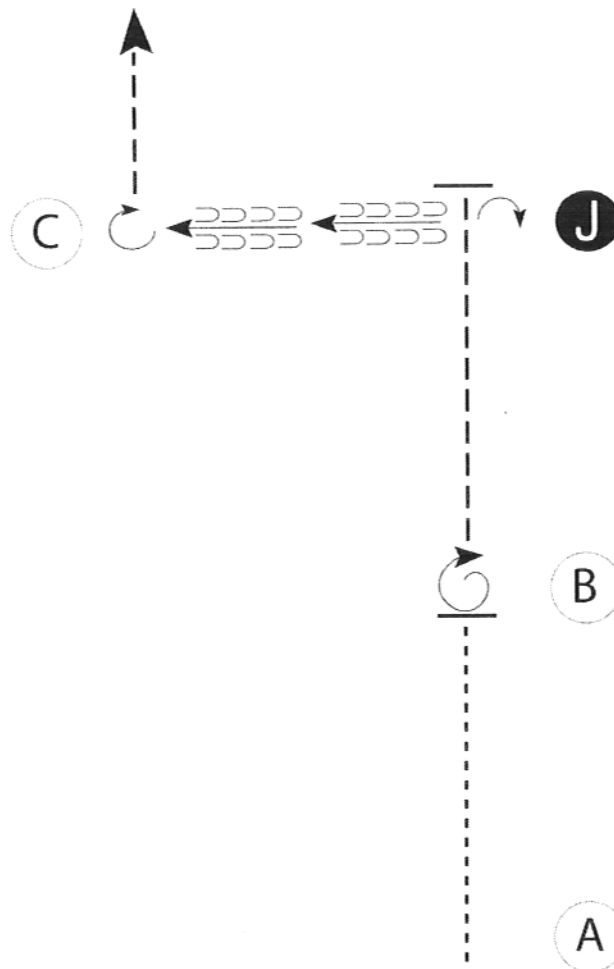

Be ready at A.

1. Walk A to B.
2. Stop at B and perform a 360 degree turn.
3. Trot until even with Judge.
4. Stop and perform a 90 degree turn; set up for inspection.
5. When dismissed, back to C.
6. Perform a 270 degree turn and trot straight away.

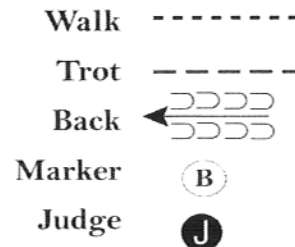

Follow the instructions of your ring steward.

[S/2-4]

Pattern Provided by:

2023 WS Finals Show

Class 90-92-96

Show Date:

www.HorseShowPatterns.com

www.HorseShowPatterns.com

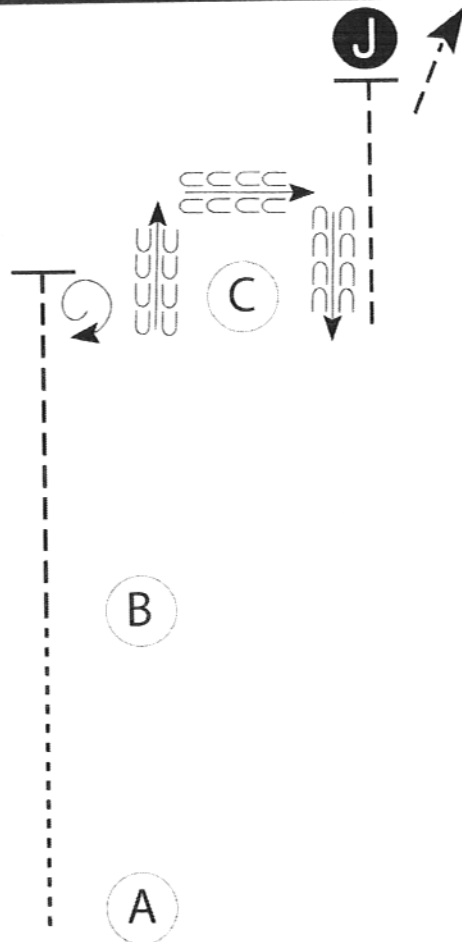

Be ready at A.

1. Walk A to B.
2. Trot from B until even with C.
3. Perform a 1 1/2 turn.
4. Back around C.
5. Trot to judge.
6. Stop and set up for inspection.
7. When excused, trot away from judge.

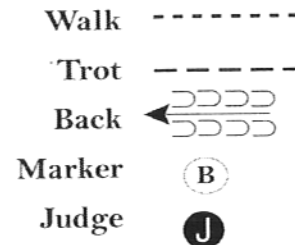

Follow the instructions of your ring steward.

[S/3-40]

Pattern Provided by:

2023 WS Finals Show

Class 91-93-94-95-97-98-99-100

Show Date:

w w w . H o r s e S h o w P a t t e r n s . c o m

w w w . H o r s e S h o w P a t t e r n s . c o m

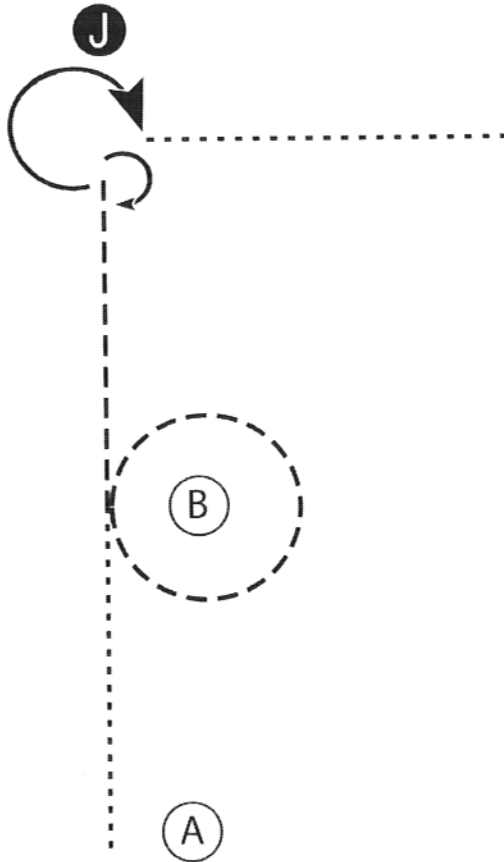

1. Walk from A to B.
2. At B trot. Trot a circle around B and continue to the Judge.
3. Stop and perform a 180 degree turn. Set up for inspection.
4. When dismissed perform a 270 degree turn.
5. Walk straight away from the Judge.

Walk
Trot	- - - - -
Back	← ≡≡≡≡≡ ≡≡≡≡≡
Marker	(B)
Judge	(J)

[S/2-9]

Pattern Provided by:

RANCH RIDING
CLASS 109
WALK TROT

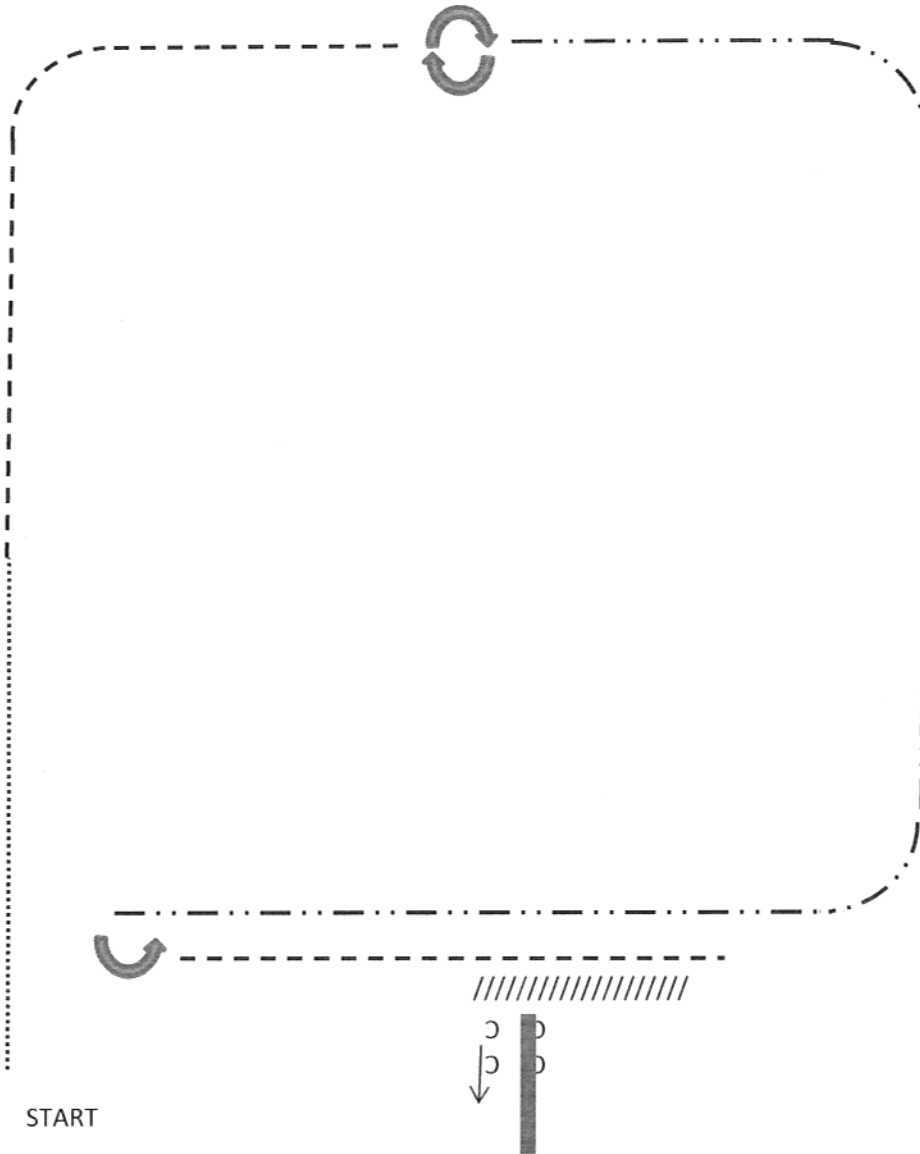

START

USE ONLY 1/2 of Arena

- | | |
|------------------|--------------------------|
| 1. Walk | 5. Stop, 180 Left |
| 2. Trot | 6. Trot, past center |
| 3. 360 Right | 7. Stop & Back to center |
| 4. Extended Trot | 8. Side Pass Rail Right |



2023 WS Finals Show

Ranchmanship Class 112

Show Date:

www.HorseShowPatterns.com

www.HorseShowPatterns.com

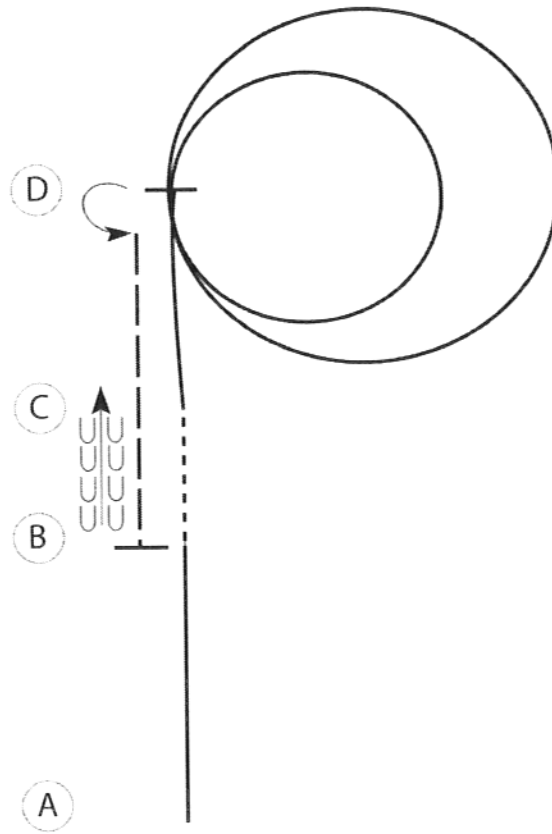

Be ready at A.

1. Lope on the left lead to B.
2. Walk B to C.
3. Lope on the right lead to D.
4. Lope a large fast circle to the right.
5. Lope a small slow circle to the right.
6. Stop at D and perform a 180 degree spin to the left.
7. Extend the jog to B.
8. Stop at B and back to C.

Follow the instructions of your ring steward.

Walk	-----
Jog	-----
Extended Jog	-----
Lope	-----
Leg Yield	
Lead Change	↗ ↘
Back	← ← ← ←
Marker	⊙ B
Sidepass	←-----→

[WH/3-1]

Pattern Provided by:

2023 WS Finals Show

Class 122

Show Date:

www.HorseShowPatterns.com

www.HorseShowPatterns.com

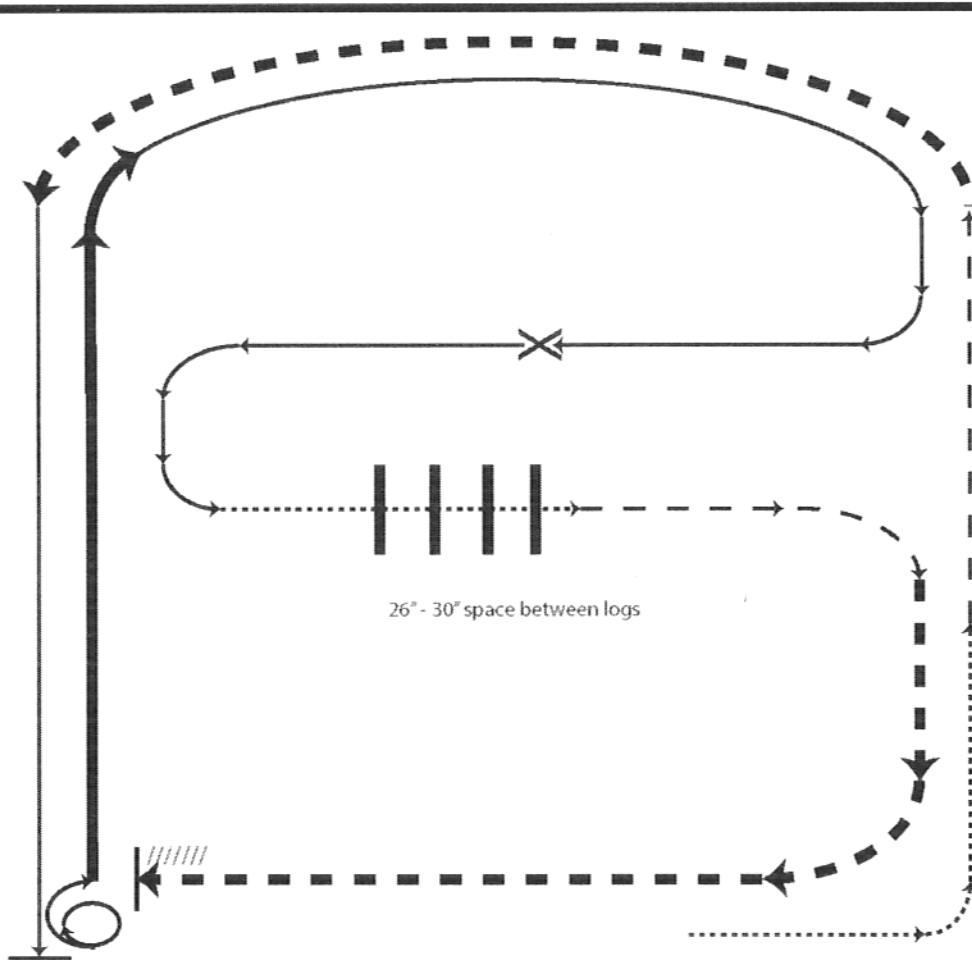

- X Lead Change
- Walk
- - - Trot
- · · Ext Trot
- Lope
- Ext Lope
- /////// Back

1. Walk
2. Trot
3. Extended trot
4. Left lead lope
5. Stop, 1 1/2 turn right
6. Extended lope
7. Collect to working lope-right lead
8. Change leads (simple or flying)
9. Walk
10. Walk over logs
11. Trot
12. Extended trot
13. Stop and back

[RR/AQHA-2]

Pattern Provided by:

2023 WS Finals Show

Class 123-125-126

Show Date:

www.HorseShowPatterns.com

www.HorseShowPatterns.com

LEVEL I WESTERN RIDING PATTERN 7

LEGEND

.....	Walk
- - - -	Jog
————	Lope
///////	Back
————	Lead Changing Area

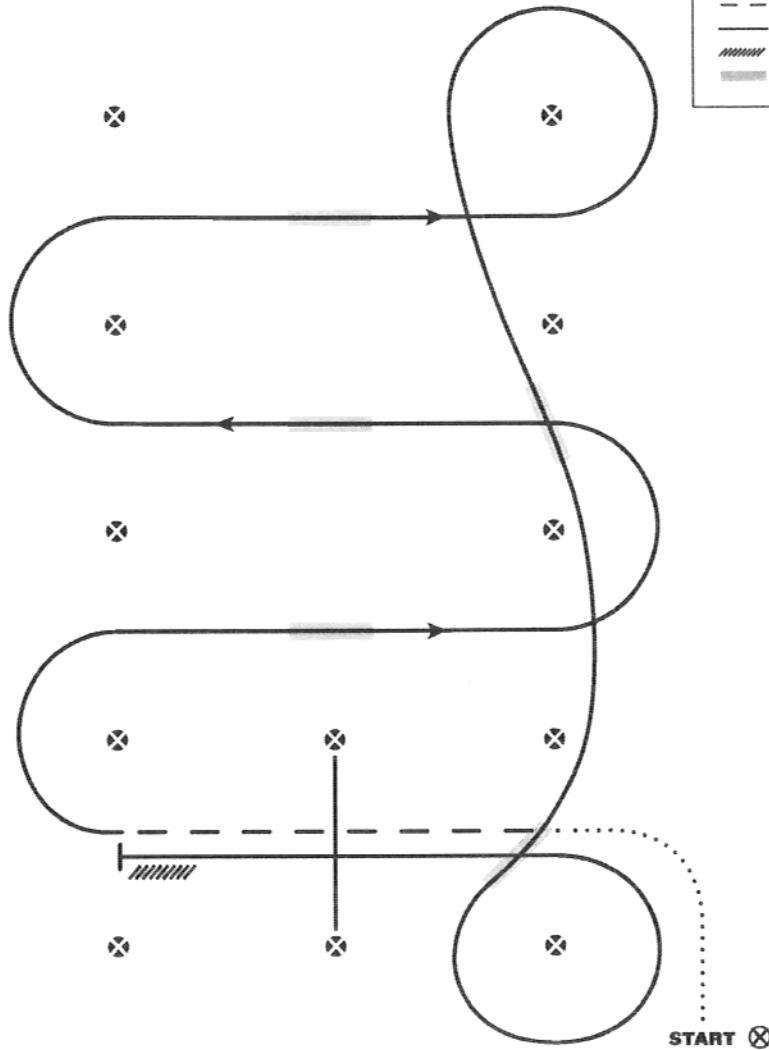

1. Walk at least 15 feet from start cone to the first marker, as drawn, transition to jog, jog over log.
2. Transition to the lope right lead
3. First crossing change
4. Second crossing change
5. Third crossing change
6. Circle & first line change
7. Second line change & circle
8. Lope over log
9. Stop & back

Revised 06-07-2021

[WR/GP-7]

Pattern Provided by:

2023 WS Finals Show

Class 124

Show Date:

www.HorseShowPatterns.com

www.HorseShowPatterns.com

WESTERN RIDING - PATTERN 7

LEGEND

.....	Walk
- - - -	Jog
————	Lope
//////	Back
▨▨▨▨	Lead Changing Area

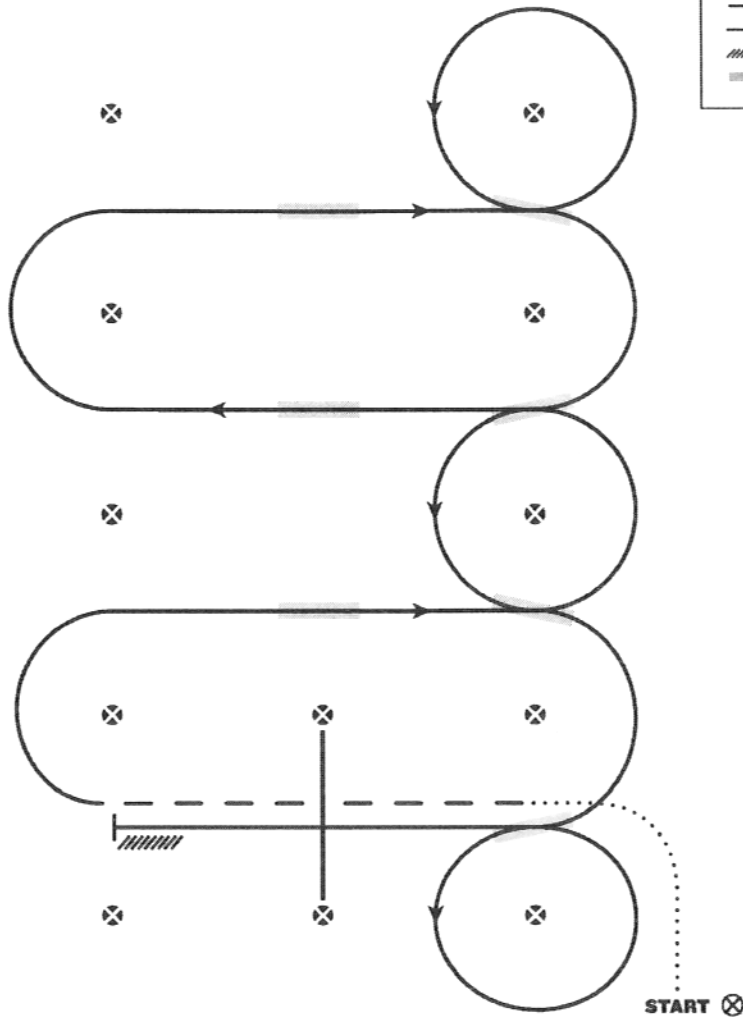

1. Walk at least 15 feet from start cone to the first marker, as drawn, transition to jog, jog over log.
2. Transition to the lope right lead
3. First crossing change
4. Second crossing change
5. Third crossing change
6. Circle & first line change
7. Second line change
8. Third line change
9. Fourth line change & circle
10. Lope over log
11. Lope, stop & back

Revised 06-07-2021

Pattern Provided by:

[WR/OP-7]

2023 WS Finals Show

Class 148-149-154

Show Date:

www.HorseShowPatterns.com

www.HorseShowPatterns.com

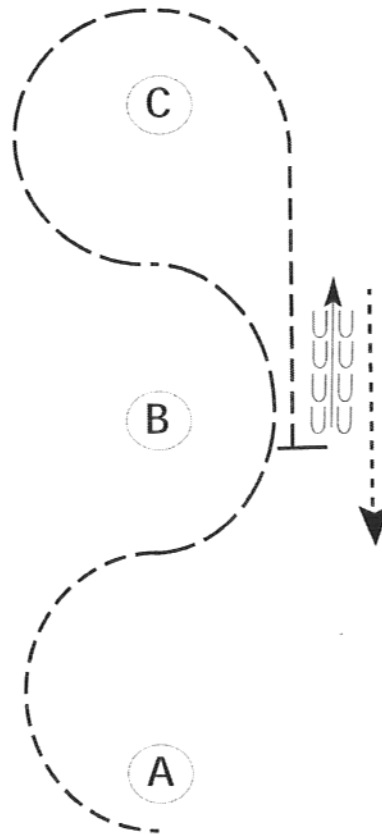

Be ready at A.

1. Jog in a half circle until between A and B.
2. Extend the jog around B and C as shown.
3. Slow to a jog and jog until even with B.
4. Stop and back approximately one horse length.
5. Walk straight away.

Follow the instructions of your ring steward.

Walk	-----
Jog	- - - - -
Extended Jog	— — — —
Lope	—————
Lead Change	
Back	
Marker	ⓑ

[WH/WT-85]

Pattern Provided by:

2023 WS Finals Show

Class 150-155

Show Date:

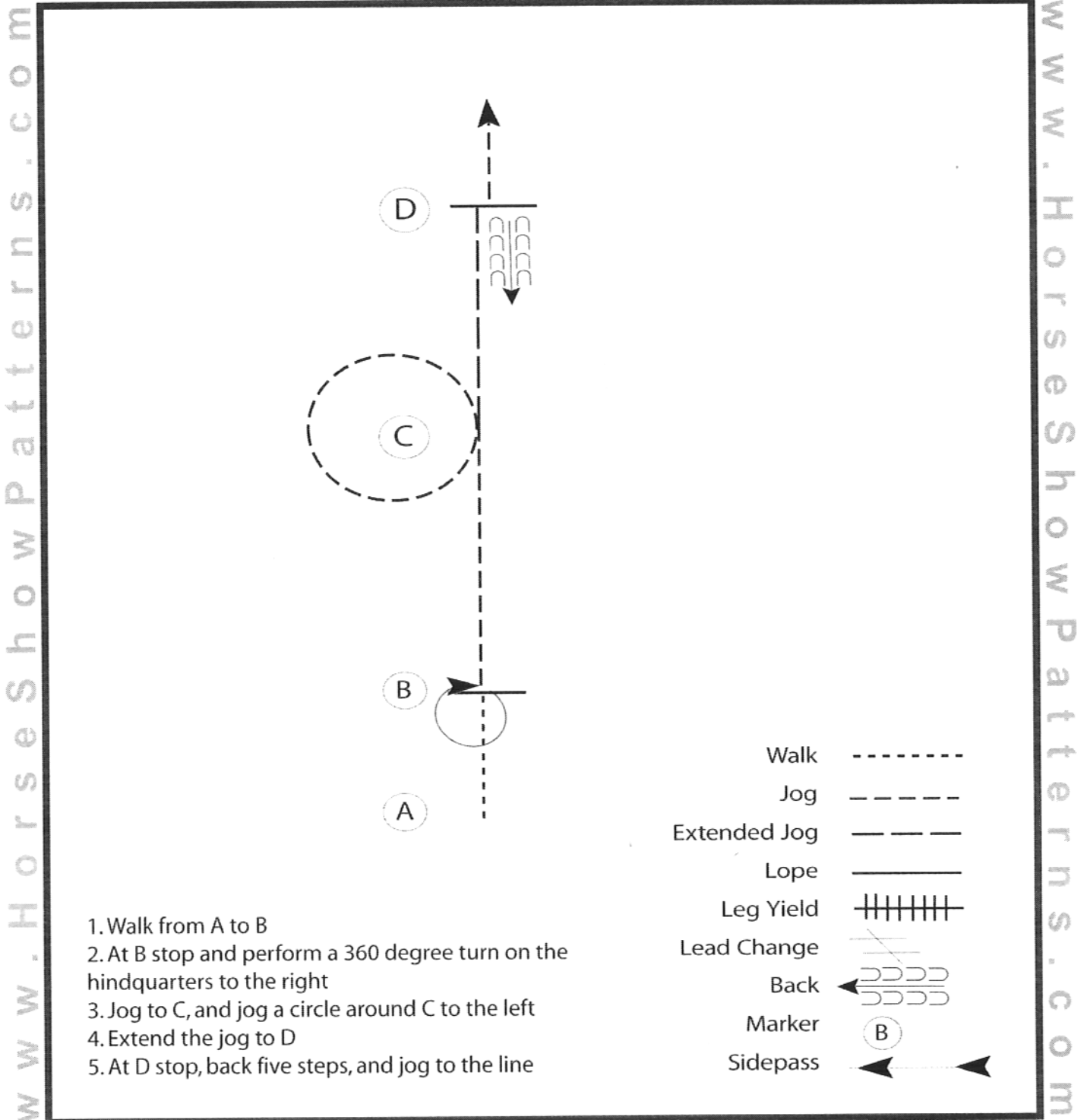

1. Walk from A to B
2. At B stop and perform a 360 degree turn on the hindquarters to the right
3. Jog to C, and jog a circle around C to the left
4. Extend the jog to D
5. At D stop, back five steps, and jog to the line

Walk
Jog	-----
Extended Jog	-----
Lope	—————
Leg Yield	
Lead Change	—/—
Back	←←←←←
Marker	(B)
Sidepass	←-----→

[WH/WT-15]

Pattern Provided by:

2023 WS Finals Show

Class 152-157-159-160-161-162

Show Date:

www.HorseShowPatterns.com

www.HorseShowPatterns.com

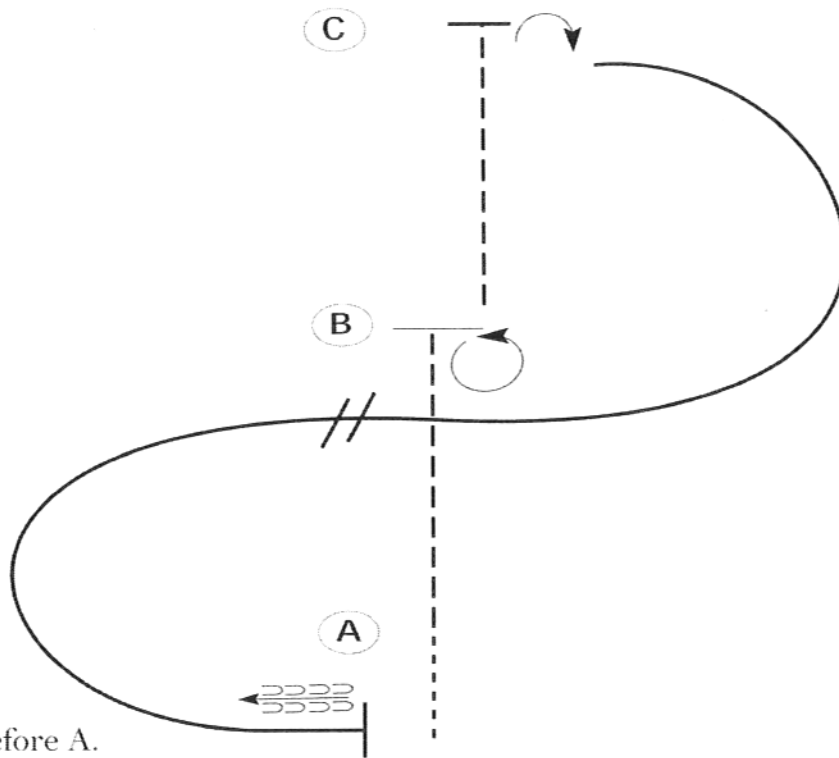

Be ready before A.

1. Walk to A.
2. Jog A to B.
3. Stop at B and perform a 360 degree turn to the left.
4. Perform an extended jog from B to C.
5. Stop at C and turn 90 degrees to the right.
6. Lope a half circle to B on the right lead.
7. At B perform a flying lead change and lope a half circle to A on the left lead.
8. Stop at A and back approximately one horse length.

Follow the instructions of your ring steward.

Walk	-----
Jog	- - - - -
Extended Jog	— — — —
Lope	—————
Leg Yield	
Lead Change	⚡
Back	←←←←← ←←←←←
Marker	⊙ B
Sidepass	←←←←←

[WH/3-30]

Pattern Provided by:

2023 WS Finals Show

Class 151-156

Show Date:

www.HorseShowPatterns.com

www.HorseShowPatterns.com

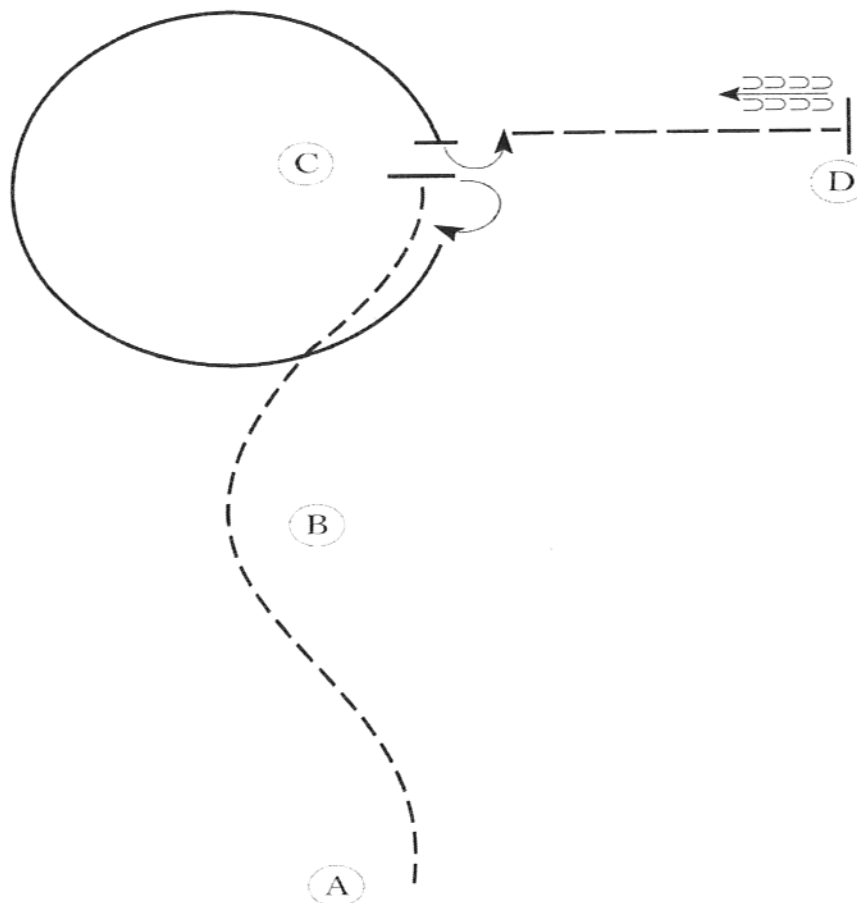

1. Jog A to C.
2. Stop at C and perform a 180 degree turn to the right
3. Lope a circle around C on the right lead.
4. Stop at C and perform a 90 degree turn to the left.
5. Extended jog to D.
6. Stop at D and back approximately one horse length.

Walk
Jog	-----
Extended Jog	- - - - -
Lope	—————
Lead Change	— / —
Back	←←←←←
Marker	ⓑ

Follow the instructions of your ring steward.

[WH/1-1]

Pattern Provided by:

2023 WS Finals Show

Class 153-158

Show Date:

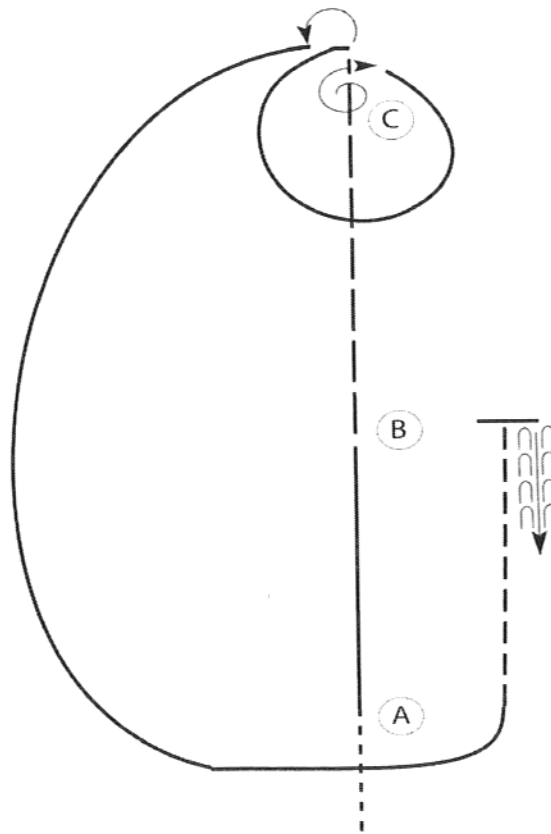

Be ready before A.

1. Walk to A.
2. At A, lope on the left lead to B.
3. At B, extend the jog to past C.
4. Stop and perform a 450 degree turn to the right.
5. Lope a circle around C on the right lead.
6. Stop at C and perform a 180 degree turn to the left.
7. Lope a large fast half circle to and around A .
8. At A, jog to B.
9. Stop at B and back 4 approximately one horse length.

Walk	-----
Jog	-----
Extended Jog	-----
Lope	—————
Lead Change	———/———
Back	←————
Marker	(B)

[WH/3-8]

Pattern Provided by:

2023 WS Finals Show

Bareback 163

Show Date:

www.HorseShowPatterns.com

www.HorseShowPatterns.com

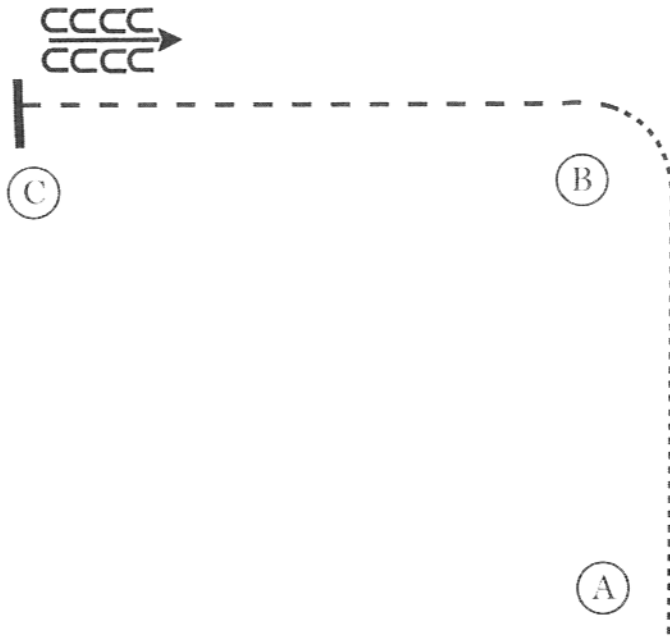

1. Walk A to B
2. Jog B to C
3. At C stop and back

Walk
Jog	- - - - -
Extended Jog	- - - - -
Lope	—————
Leg Yield	
Lead Change	
Back	
Marker	(B)
Sidepass	- - - - -

[WH/WT-4]

Pattern Provided by:

2023 WS Finals Show

Bareback 164

Show Date:

www.HorseShowPatterns.com

www.HorseShowPatterns.com

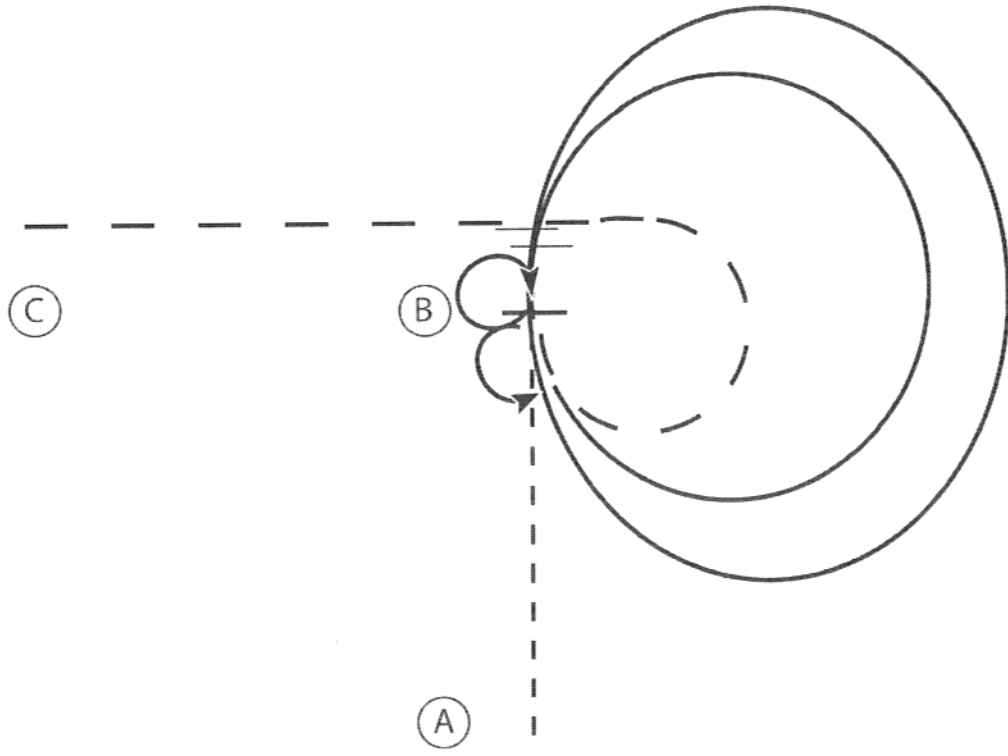

1. Jog A to B
2. Stop at B and perform a 180 degree turn to the left
3. Lope a small slow circle to the left on the right lead
4. At B perform a lead change and lope a larger faster circle to the left
5. Stop at B and perform a 360 degree turn to the right
6. Extend the jog in a circle and then continue on the C
7. Stop at C

Walk
Jog	-----
Extended Jog	— — — —
Lope	————
Leg Yield	
Lead Change	↘
Back	←←←←
Marker	(B)
Sidepass	←←←←

[WH/3-12]

Pattern Provided by:

2023 WS Finals Show

Class 170-171

Show Date:

www.HorseShowPatterns.com

www.HorseShowPatterns.com

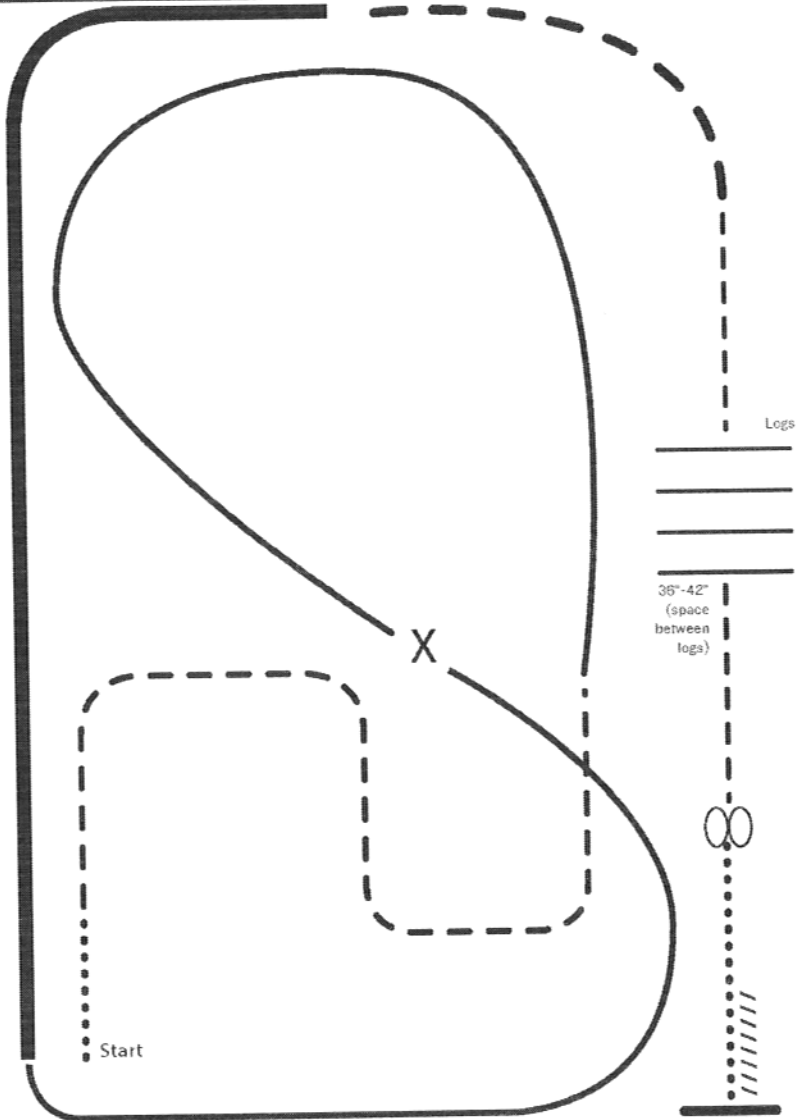

- X Lead Change
- Walk
- - - Trot
- - - Ext trot
- — — — — Lope
- — — — — Ext Lope
- //// //// Back

1. Walk
2. Trot serpentine
3. Lope left lead around the end of the arena and then diagonally across the arena
4. Change leads (simple or flying) and
5. Lope on the right lead around end of the arena
6. Extend lope on the straight away and around corner to the center of the arena
7. Extend trot around corner of the arena
8. Collect to a trot
9. Trot over logs
10. Stop, do 360 degree turn each direction (either direction 1st) (L-R or R-L)
11. Walk, stop and back

[RR/AQHA-3]

Pattern Provided by:

2023 WS Finals Show

Class 172-173-174-175-176

Show Date:

www.HorseShowPatterns.com

www.HorseShowPatterns.com

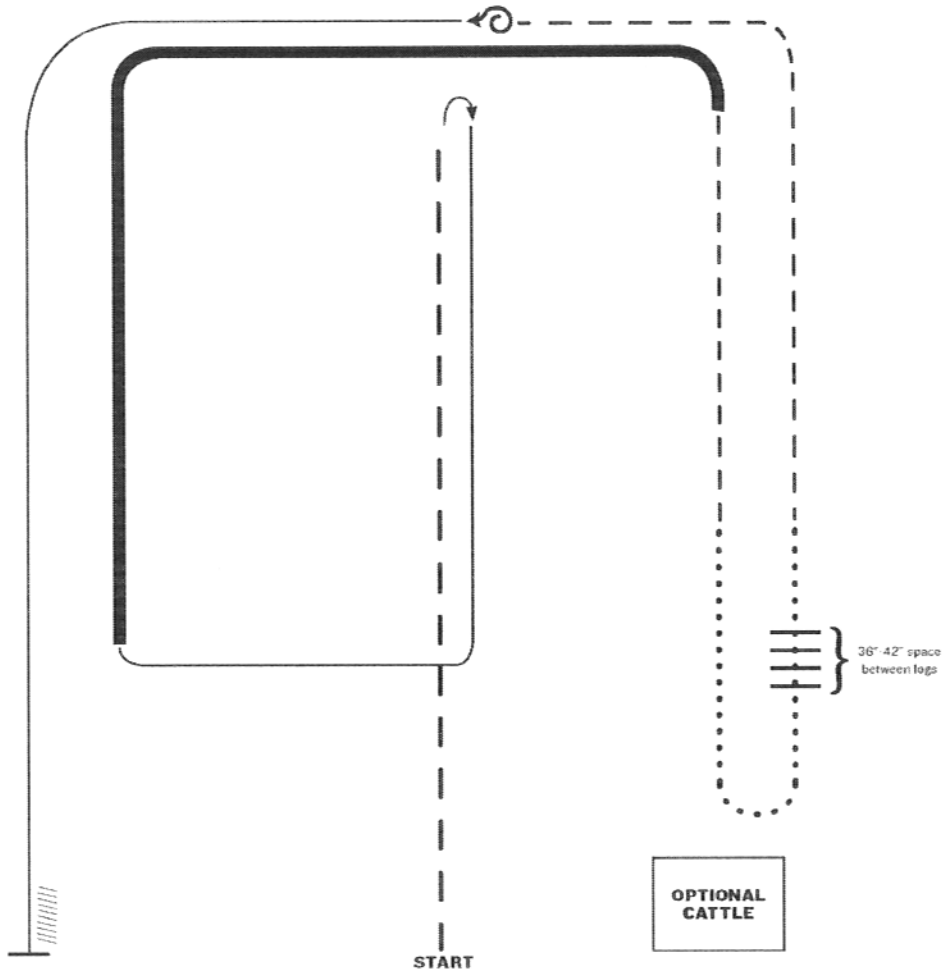

1. Extended trot
2. Stop, rollback right
3. Lope right lead
4. Extended lope (right lead)
5. Trot
6. Walk
7. Walk over logs
8. Walk
9. Trot
10. Stop, 360 left
11. Lope left lead
12. Stop and back

Note: The drawn description of this pattern is only intended for the general depiction of the pattern. Exhibitors should utilize the arena space to best exhibit their horses.

OPTIONAL
CATTLE

[RR/AQHA-15]

Pattern Provided by:

2023 WS Finals Show

Class 4-5-7

Show Date:

w w w . H o r s e S h o w P a t t e r n s . c o m

w w w . H o r s e S h o w P a t t e r n s . c o m

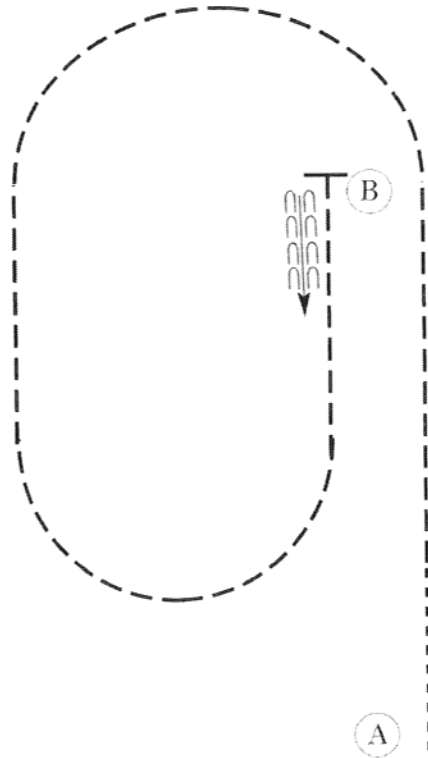

Be ready at A.

1. Walk two horse lengths from A.
2. Posting trot on the left diagonal to B.
3. Change diagonals and posting trot on the right diagonal in a half circle and then in a straight line until halfway between B and A.
4. Sitting trot a half circle and then a straight line to B.
5. Stop and back approximately one horse length.

Follow the instructions of your ring steward.

Walk	-----
Trot	-----
Extended Trot	-----
Canter	-----
Leg Yield	
Lead Change	↘
Back	←←←←
Marker	Ⓚ
Sidepass	←-----→
Hand Gallop	-----

[HSE/WT-58]

Pattern Provided by: